

Test Stand for MRO

Trust to test > trust to flight

Universal Hydraulic Test Stand PN: HPHT021001-8



Test Stand for MRO

Trust to test > trust to flight

Universal Hydraulic Test Stand > HPHT021001-8 <

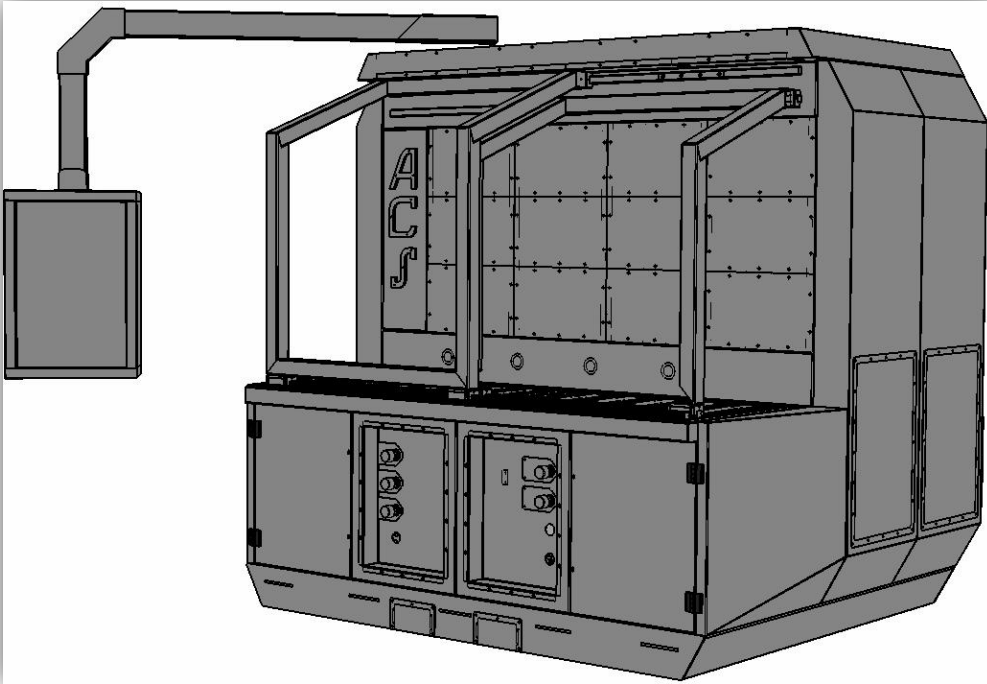

Universal Hydraulic Test Stand

Purpose and Scope:

- > The equipment is design to test different hydraulic components for trouble free function.
- > Testing of:
 - Valves
 - Linear ACT
 - Solenoid Valves
 - Pressure Switches
- > Ergonomically designed test and operation area
- > Manual and automatic test procedures.
- > It can be adapted for other aircraft types.

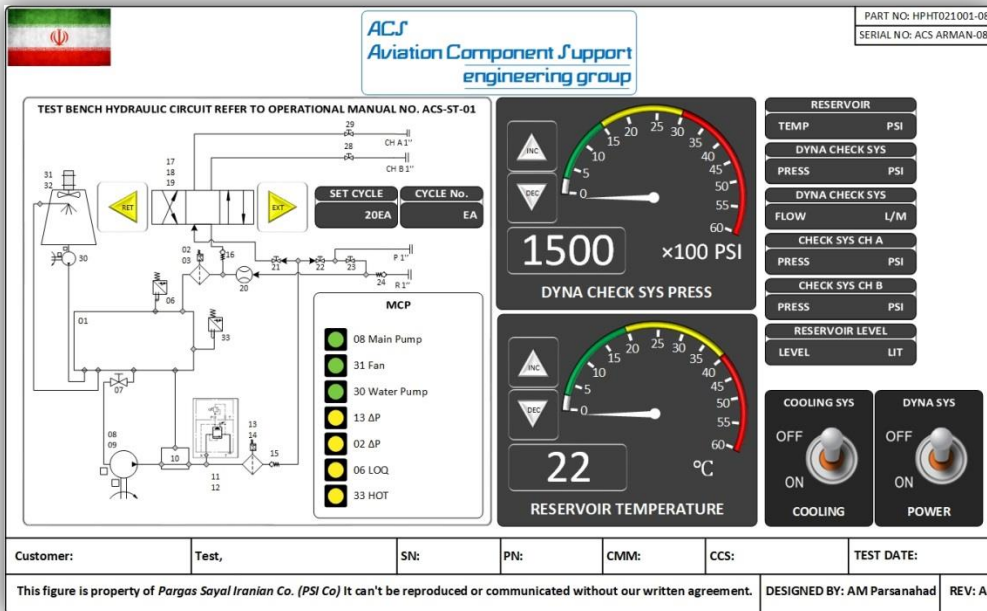

Universal Hydraulic Test Stand Monitor Display

General information

- > Profile frame, and front panels and doors or covers of iron.
- > Big clamping bed for diverse adaptations for UUT mounting.
- > Sliding doors of secured glass (SG) to protect the user.
- > Colorless front panels with labelling (English) are permanently resistant against mineral and synthetic oils, fuels and cleaning detergents.
- > Remote Test Report of the test stand by the Bluetooth connection.
- > Compact setup and easy accessibility for maintenance tasks.

Requirement :

Electric,	3/N/PE AC 50Hz 400V Nominal current: 100A Preliminary fuse: 100A
-----------	------------------------------------------------------------------------

Compressed air:

Pressure,	NA
-----------	----

Flow,	NA
-------	----

Dimension:

Width,	2369mm
Depth,	1700mm
Height,	2105mm without HMI holder

Pressure measurements:

Measuring circuit 1:
 0 to 206bar (0 to 3000 psi)
 0 to 10bar (0 to 145.0psi)
 0 to 60bar (0 to 870.2psi)

Measuring circuit 2:
 CHA 0 to 206bar (0 to 3000 psi)
 CHB 0 to 206bar (0 to 3000 psi)

Flow measurements:

Flow measuring track 1: 0.0 to 60 l/min
 (0.0 to 15 USgpm)

Flow measuring track 2: NA

Temperature measurements:

Track 1: 0 to +90°C

Track 2: NA

شرکت پرکاس سیال ایرانیان

تلفن: ۰۹۹۰۲۲۸۸۶۷۱-۰۹۱۲۰۶۶۵۲۹۳

آدرس کارگاه: کهریزک - جاده قدیم قم - شکت متری امام حسین - خیابان پنجم شمالی - پلاک ۱۳

www.psi-ac.com